

Reduced-Tip Van Stone Thermowells are available in a variety of materials, flange sizes, and pressure ratings. They are also offered in various lengths and with optional lagging extensions. Thermowell specifications should be determined based on process conditions which include strength, temperature, pressure and corrosion-resistance requirements. The Reduced Tip Van Stone thermowell is supplied with a 0.260" bore diameter to accommodate sensing elements with a 0.252" maximum diameter. The stepped construction is normally used in standard-duty applications and increases the speed of response while maintaining mechanical strength. Van Stone thermowells are connected using a separate and reusable backing flange, eliminating the need for expensive flange materials. These wells are available as separate components or as part of complete sensor assemblies.

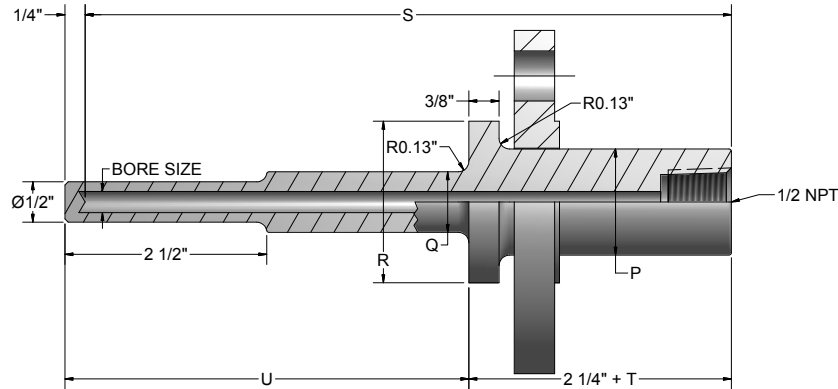

**Thermowell Dimensions**

"P" PIPE SIZE NOM.	"p" DIA.	"R" DIA.	"Q" DIA.
1"	1.315"	2"	3/4"
1 1/2"	1.900"	2 7/8"	7/8"

("U" length for non-lagging wells) = "S" - 2"

("U" length for lagging wells) = "S" - 2" - "T"

(To solve for "T"), "T" = "S" - "U" - 2" (When "U" and "S" are specified)

### ORDER CODES

**Example Order Number:**

1-0 1-1 1-2 1-3 1-4 1-5 1-6 1-7 1-8  
**RF 4 15 V 1 09 08 T2 C8S**

**1-0 Well Type**

CODE	DESCRIPTION
RF	Reduced-Tip Van Stone

**1-1 Bore Size**

CODE	DESCRIPTION
4	0.260" Dia. bore

**1-2 Flange Size**

CODE	DESCRIPTION
10	1" (DN25)
15	1 1/2" (DN40)

**1-3 Flange Type**

CODE	DESCRIPTION
V	Van Stone (lap joint)

**1-4 Pressure Rating**

CODE	DESCRIPTION
0	No backing flange
1	150 Class
3	300 Class
6	600 Class
9	900 Class
15	1500 Class
Carbon steel backing flange standard	

**1-8 Options**

CODE	DESCRIPTION
C8	316 stainless steel well cap and chain
C22	Brass well cap and chain
S	Well stamped with customer-specified part number

**1-7 Optional "T" Lag Dimension**

CODE	DESCRIPTION
	Leave blank if no lag is required
T__	Specify "T" dimension in inches

**1-6 Material**

CODE	DESCRIPTION
XX	Specify two digit material code as stated in the Thermowell Material Table located earlier in section

**1-5 "S" Length**

CODE	DESCRIPTION
XX	Specify length in inches using two digits plus fractional length