

Reduced-Tip, Flanged Thermowells are available in a variety of materials, flange types, flange sizes, and pressure ratings. They are also available in various lengths and with optional lagging extensions. Thermowell specifications should be determined based on process conditions which include strength, temperature, pressure and corrosion-resistance requirements. The stepped construction is normally used in standard-duty applications, and increases the speed of response while maintaining mechanical strength. They are designed with standard 0.260" bore diameters to accommodate sensing elements with a 0.252" maximum diameter. These wells are available as separate components or as part of complete sensor assemblies.

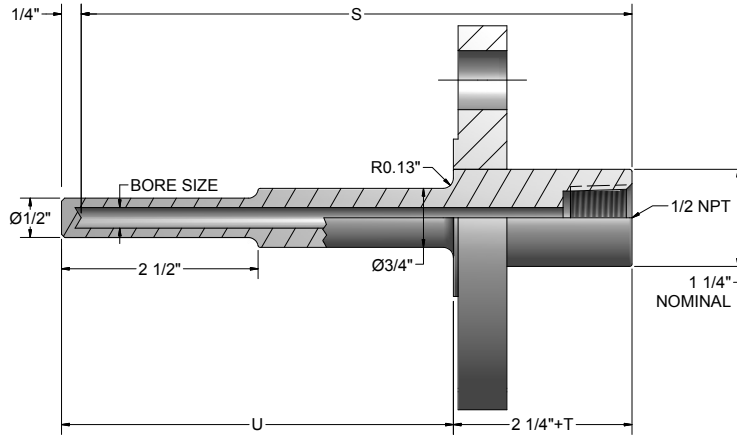

("U" length for non-lagging wells) = "S" - 2"
 ("U" length for lagging wells) = "S" - 2" - "T"
 (To solve for "T"), "T" = "S" - "U" - 2" (When "U" and "S" are specified)

ORDER CODES

Example Order Number:

1-0 1-1 1-2 1-3 1-4 1-5 1-6 1-7 1-8
RF 4 15 R 1 09 08 T2 C8S

1-0 Well Type

CODE	DESCRIPTION
RF	Reduced-tip flanged

1-1 Bore Size

CODE	DESCRIPTION
4	0.260" Dia. bore

1-2 Flange Size

CODE	DESCRIPTION
10	1" (DN 25)
13	1 1/4" (DN 32)
15	1 1/2" (DN 40)
20	2" (DN 50)
30	3" (DN 80)

1-3 Flange Type

CODE	DESCRIPTION
F	Flat face
J	Ring joint
R	Raised face

1-4 Pressure Rating

CODE	DESCRIPTION
1	150 Class
3	300 Class
6	600 Class
9	900 Class
15	1500 Class

1-8 Options

CODE	DESCRIPTION
C8	316 stainless steel well cap and chain
C22	Brass well cap and chain
F	Full penetration weld
S	Well stamped with customer specified part number

1-7 Optional "T" Lag Dimension

CODE	DESCRIPTION
	Leave blank if no lag is required
T__	Specify "T" dimension in inches

1-6 Material

CODE	DESCRIPTION
XX	Specify two digit material code as stated in the Thermowell Material Table located earlier in section

1-5 "S" Length

CODE	DESCRIPTION
XX	Specify length in inches using two digits plus fractional length