

Thermowells

Sanitary Weld-In Thermowells

Sanitary Weld-In Thermowells are offered in 304 and 316 stainless steel. They are available in a variety of lengths, process connection sizes, and with optional lagging extensions. The thermowell is to be welded into a tank or vat with a full crevice free fillet-weld to prevent corrosion, bacteria growth, and product contamination. Thermowells are supplied with a surface finish that meets or exceeds 32µin R_a. Surface finishes of 15µin R_a or better are available upon request. They are designed with standard 0.260" and 0.385" bore diameters to accommodate sensing elements with a 0.252" or 0.377 maximum diameters. These wells are available as a separate component or as part of a complete sensor assembly.

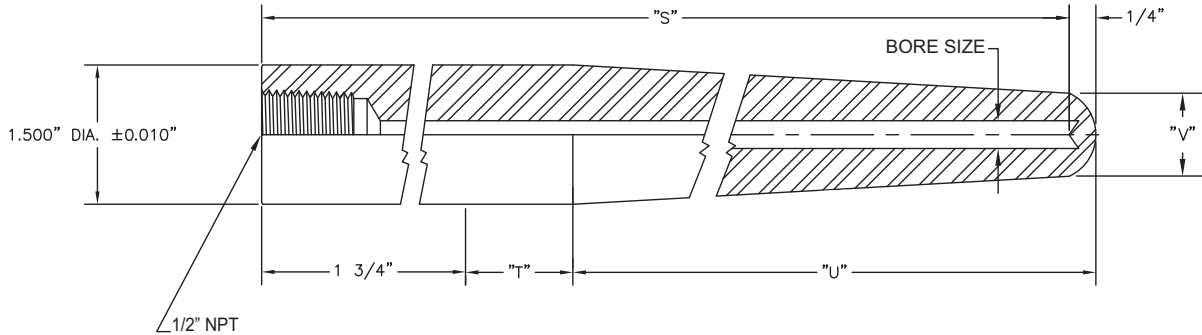

Thermowell Dimensions

BORE SIZE	"V"
0.260" Dia.	5/8" Dia.
0.385" Dia.	49/64" Dia.

("U" length for non-lagging wells) = "S" - 1 1/2"
 ("U" length for lagging wells) = "S" - 1 1/2" - "T"
 (To solve for "T"), "T" = "S" - "U" - 1 1/2" (When "U" and "S" are specified)

ORDER CODES

Example Order Number:

1-0 1-1 1-2 1-3 1-4 1-5 1-6
WS 4 09 08 T2 C8S

1-0 Well Type

CODE	DESCRIPTION
WS	Sanitary weld-in

1-1 Bore Size

CODE	DESCRIPTION
4	0.260 Dia. bore
6	0.385 Dia. bore

1-2 "S" Length

CODE	DESCRIPTION
XX	Specify length in inches using two digits plus fractional length

1-5 Options

CODE	DESCRIPTION
C8	316 stainless steel well cap and chain
C22	Brass well cap and chain
S	Well stamped with customer specified part number

1-4 Optional "T" Lag Dimension

CODE	DESCRIPTION
	Leave blank if no lag is required
T__	Specify "T" dimension in inches

1-3 Material

CODE	DESCRIPTION
08	316 stainless steel
09	304 stainless steel