

# Non-Intrusive Tri-Clamp RTD Sensor



This sensor is designed to mount flush with the interior of the tank wall for maximum product contact. This allows the wiping or mixing blades to properly mix the product within the tank without damaging the temperature sensor. The Temperature Sensor is manufactured of highly polished stainless steel and utilizes standard tri-clamp mounting connections.

**Pyro**MATION, INC.  
*Quality in Every Degree®*

# Non-Intrusive Tri-Clamp RTD Sensor

Effective Date 06-09  
Discount Schedule A  
Configuration Code TS01

The Non-Intrusive Tank Sensor is a 100 Ω, Platinum RTD sensing element. This sensor assembly is constructed of 316 stainless steel and supplied with a Silicone/Teflon® O-ring seal. All wetted parts are supplied with a surface finish that meets or exceeds 32 μin R<sub>a</sub>. Surface finishes of 15 μin R<sub>a</sub> or better are available upon request. This sensor has an operating temperature of (-40 to 204) °C [-40 to 400] °F.

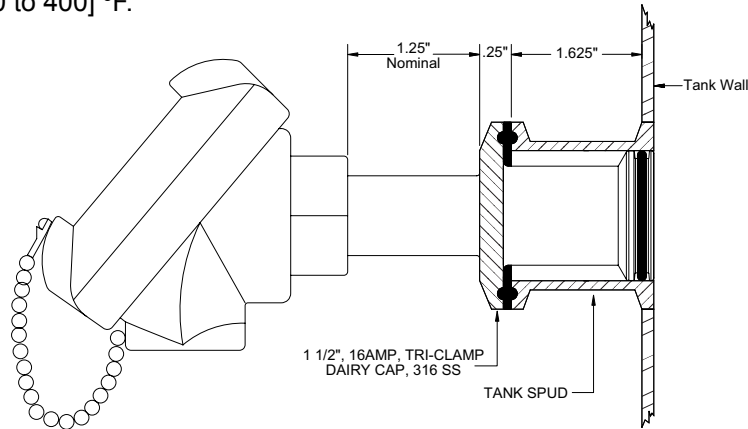

**Example Order Number:** 1-0 **RBF185L3** 1-1 **3** - 1-2 **TTA** - 1-3 **63**

## 1-0 100 Ω Platinum RTD Elements

CODE		INITIAL ELEMENT ACCURACY 0 °C	TEMPERATURE COEFFICIENT
SINGLE	DUPLEX		
RBF185L3	RBF285L3	± 0.12%	α = 0.003 85 °C <sup>-1</sup>
RAF185L3	RAF285L3	± 0.06%	α = 0.003 85 °C <sup>-1</sup>

## 1-1 Element Connection

CODE	DESCRIPTION
3	3 Wire
4 <sup>[1]</sup>	4 Wire
[1] Not available in duplex.	

## 1-2 Assembly Options

CODE	DESCRIPTION
TTA	Complete Assembly, includes sensor, mounting adaptor, clamp, O Ring, and gasket
TTS	Replacement Sensor, includes sensor and O Ring

## 1-3 Head Terminations

CODE	DESCRIPTION
31,W	Aluminum screw cover head with Epoxy Coating
62	White DIN form B polypropylene head
63	White polypropylene head
91	316 L stainless steel screw cover head
92	DIN form B 316 stainless steel screw cover head
T	Head Mounted Transmitter. See Transmitter section of catalog for complete offering.

## Replacement Parts

CODE	DESCRIPTION
A107605	Tank Mounting Adaptor
460185	Silicon/Teflon O Ring
430002	1-1/2" Clamp
430003	EDPM Gasket

## Installation Instruction for TTS Series

1. Drill a 2.00" hole through the tank wall for tank spud.
2. Bevel tank wall(s) and/or tank adaptor as needed.
3. Tack weld (GTAW preferred) tank spud 3 to 4 places to inside of tank wall to ensure flush/square fit.
4. Seal weld (GTAW preferred) tank spud to inside tank wall, grind weld as needed, provide sanitary finish to 180 grit minimum
5. Weld (GTAW preferred) tank spud to outside of tank wall, grind weld as needed.
6. Slide O-ring onto sensor housing assembly.
7. Insert Assembly into tank spud and tighten clamp.

**Pyromation, Inc.**

5211 Industrial Road, Fort Wayne, IN 46825 USA  
Phone: (260) 484-2580 • Fax: (800) 837-6805 or (260) 482-6805  
www.pyromation.com